

Model			GWH18AGD-K6DNA1E GWH18AGD-K6DNA2E	GWH18AGD-K6DNA1E
Product Code			CB385009100 CB543000800	CB385009101
Power Supply	Rated Voltage	V~	220-240	220-240
	Rated Frequency	Hz	50	50
	Phases		1	1
Power Supply Mode			Outdoor	Outdoor
Cooling Capacity		W	5300	5300
Heating Capacity		W	5600	5600
Cooling Power Input		W	1501	1501
Heating Power Input		W	1393	1393
Cooling Current Input		A	7.2	7.2
Heating Current Input		A	6.3	6.3
Rated Input		W	2350	2350
Rated Cooling Current		A	10	10
Rated Heating Current		A	10.5	10.5
Air Flow Volume		m ³ /h	1000/850/760/650/580/520/450	1000/850/760/650/580/520/450
Dehumidifying Volume		L/h	1.9	1.9
EER		W/W	3.53	3.53
COP		W/W	4.02	4.02
SEER			7.3	7.3
SCOP(Average/WarmerColder)			4.2/5.7/3.5	4.2/5.7/3.5
Application Area		m ²	23-34	23-34
Indoor Unit	Model		GWH18AGD-K6DNA1E/I GWH18AGD-K6DNA2E/I	GWH18AGD-K6DNA1E/I
	Product Code		CB385N09100 CB543N00800	CB385N09100
	Fan Type		Cross-flow	Cross-flow
	Fan Diameter Length(DXL)	mm	Φ106×739	Φ106×739
	Cooling Speed	r/min	1300/1150/1030/960/800/700/650/500	1300/1150/1030/960/800/700/650/500
	Heating Speed	r/min	1300/1150/1040/950/900/880/800	1300/1150/1040/950/900/880/800
	Fan Motor Power Output	W	45	45
	Fan Motor RLA	A	0.25	0.25
	Fan Motor Capacitor	μF	/	/
	Evaporator Form		Aluminum Fin-copper Tube	Aluminum Fin-copper Tube
	Evaporator Pipe Diameter	mm	Φ5	Φ5
	Evaporator Row-fin Gap	mm	2-1.3	2-1.3
	Evaporator Coil Length (LXDXW)	mm	745×22.8×342.9	745×22.8×342.9
	Swing Motor Model		MP24AK/MP24BA/MP24HF	MP24AK/MP24BA/MP24HF
	Swing Motor Power Output	W	1.5/1.5 /1.5	1.5/1.5 /1.5
	Fuse Current	A	3.15	3.15
	Sound Pressure Level	dB (A)	Cooling:45/42/41/37/34/29/26/23 Heating:48/44/42/37/36/35/32	Cooling:45/42/41/37/34/29/26/23 Heating:48/44/42/37/36/35/32
	Sound Power Level	dB (A)	Cooling:60/55/54/50/47/42/39/36 Heating:60/57/55/50/49/48/45	Cooling:60/55/54/50/47/42/39/36 Heating:60/57/55/50/49/48/45
	Dimension (WXHxD)	mm	982X311X221	982X311X221
	Dimension of Carton Box (LXWXH)	mm	1039X377X287	1039X377X287
Dimension of Package (LXWXH)	mm	1044X385X297	1044X385X297	
Net Weight	kg	12.5	12.5	
Gross Weight	kg	15	15	

Outdoor Unit	Outdoor Unit Model		GWH18AGD-K6DNA1E/O	GWH18AGD-K6DNA1E/O
	Outdoor Unit Product Code		CB385W09100	CB385W09101
	Compressor Manufacturer		ZHUHAI LANDA COMPRESSOR CO.,LTD	ZHUHAI LANDA COMPRESSOR CO.,LTD
	Compressor Model		QXF-A120zH170A	QXF-A120zH170A
	Compressor Oil		FW68DA or equivalent	FW68DA or equivalent
	Compressor Type		Rotary	Rotary
	Compressor LRA.	A	18	18
	Compressor RLA	A	5	5
	Compressor Power Input	W	1096	1096
	Compressor Overload Protector		HPC115/95U1/KSD115°C	HPC115/95U1/KSD115°C
	Throttling Method		Electron expansion valve	Electron expansion valve
	Set Temperature Range	°C	16~30	16~30
	Cooling Operation Ambient Temperature Range	°C	-15~50	-15~50
	Heating Operation Ambient Temperature Range	°C	-15~30	-25~30
	Condenser Form		Aluminum Fin-copper Tube	Aluminum Fin-copper Tube
	Condenser Pipe Diameter	mm	Φ7	Φ7
	Condenser Rows-fin Gap	mm	2-1.4	2-1.4
	Condenser Coil Length (LXDXW)	mm	895×38.1×528	895×38.1×528
	Fan Motor Speed	rpm	880	880
	Fan Motor Power Output	W	30	30
	Fan Motor RLA	A	0.4	0.4
	Fan Motor Capacitor	μF	/	/
	Outdoor Unit Air Flow Volume	m ³ /h	2200	2200
	Fan Type		Axial-flow	Axial-flow
	Fan Diameter	mm	420	420
	Defrosting Method		Automatic Defrosting	Automatic Defrosting
	Climate Type		T1	T1
	Isolation		I	I
	Moisture Protection		IPX4	IPX4
	Permissible Excessive Operating Pressure for the Discharge Side	MPa	4.3	4.3
	Permissible Excessive Operating Pressure for the Suction Side	MPa	2.5	2.5
	Sound Pressure Level	dB (A)	56	56
	Sound Power Level	dB (A)	65	65
Dimension(WXHXD)	mm	802X555X350	802X555X350	
Dimension of Carton Box (LXWXH)	mm	869X395X594	869X395X594	
Dimension of Package(LXWXH)	mm	872X398X620	872X398X620	
Net Weight	kg	30.5	30.5	
Gross Weight	kg	33.5	33.5	
Refrigerant		R32	R32	
Refrigerant Charge	kg	0.85	0.85	
Connection Pipe	Connection Pipe Length	m	5	5
	Connection Pipe Gas Additional Charge	g/m	16	16
	Outer Diameter Liquid Pipe		1/4"	1/4"
	Outer Diameter Gas Pipe		1/2"	1/2"
	Max Distance Height	m	10	10
	Max Distance Length	m	25	25
	Note: The connection pipe applies metric diameter.			

The above data is subject to change without notice. Please refer to the nameplate of the unit.

2.2 Capacity Variation Ratio According to Temperature

GWH07AGA-K6DNA1A

Cooling

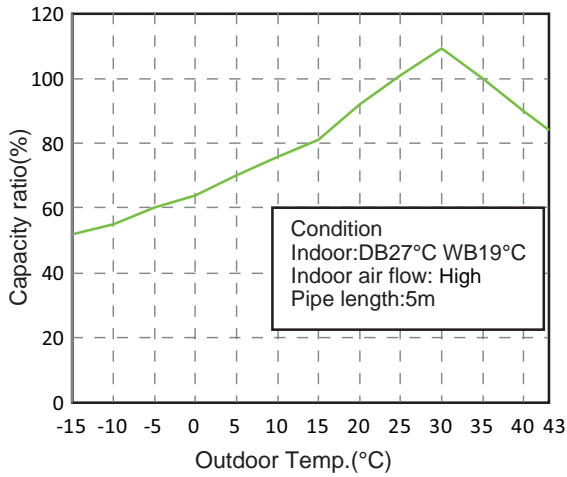

Heating

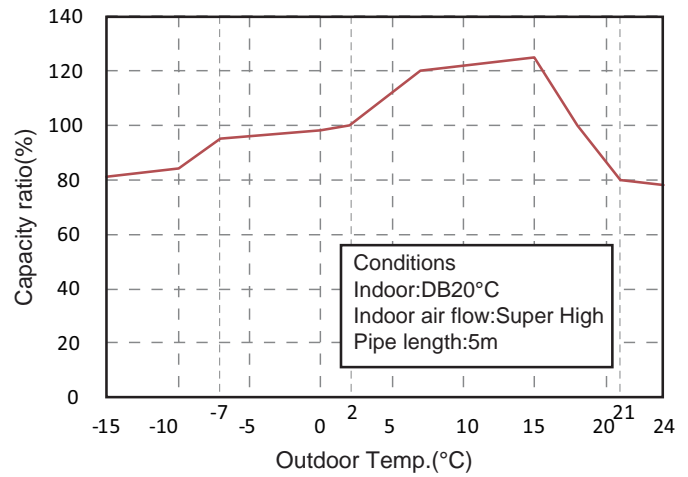

GWH18AGD-K6DNA1D GWH18AGDXB-K6DNA2D GWH18AGD-K6DNA4D GWH24AGD-K6DNA1C GWH24AGD-K6DNA4C

Heating operation ambient temperature range is -15°C~24°C

Cooling

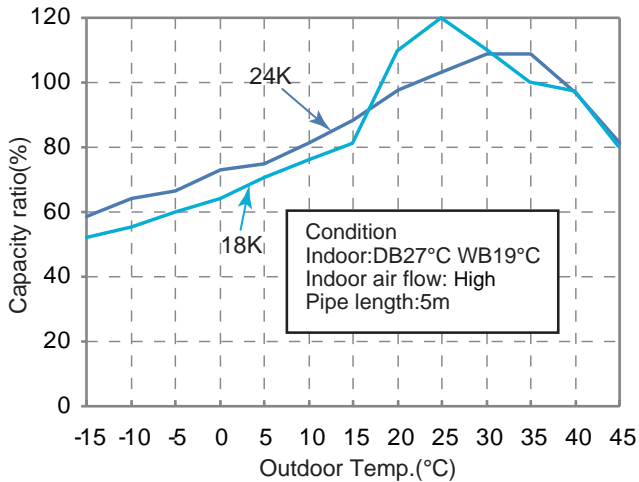

Heating

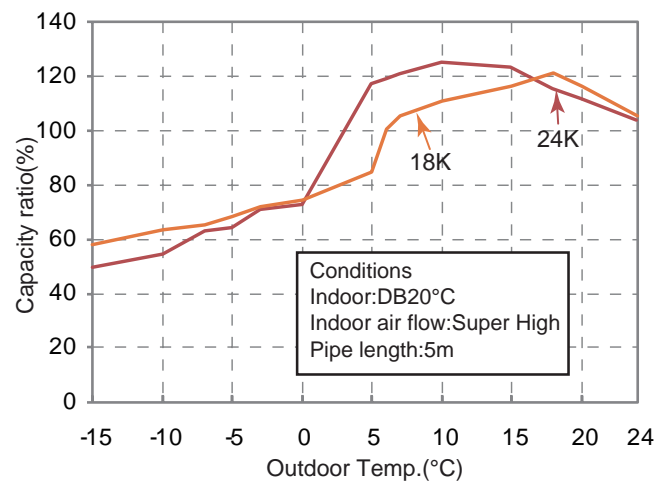

Heating operation ambient temperature range is -15°C~30°C

Cooling

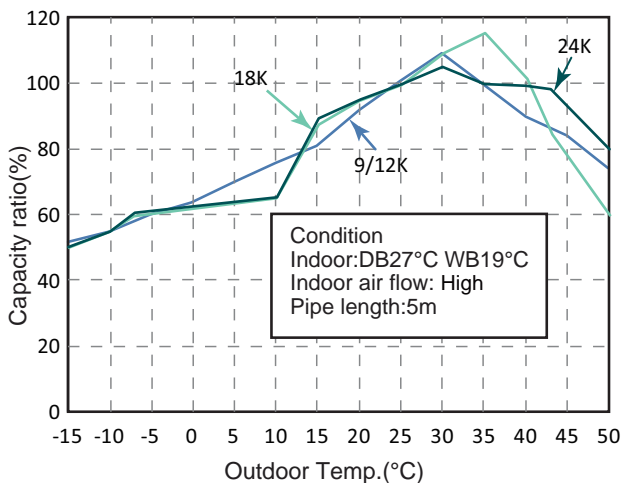

Heating

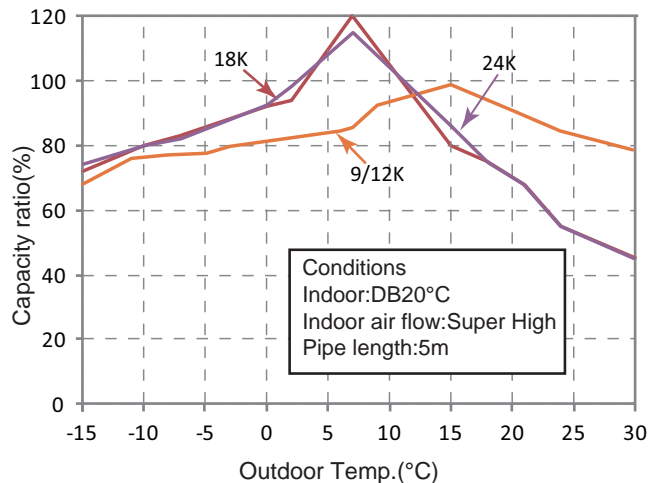

Heating operation ambient temperature range is -25°C~30°C

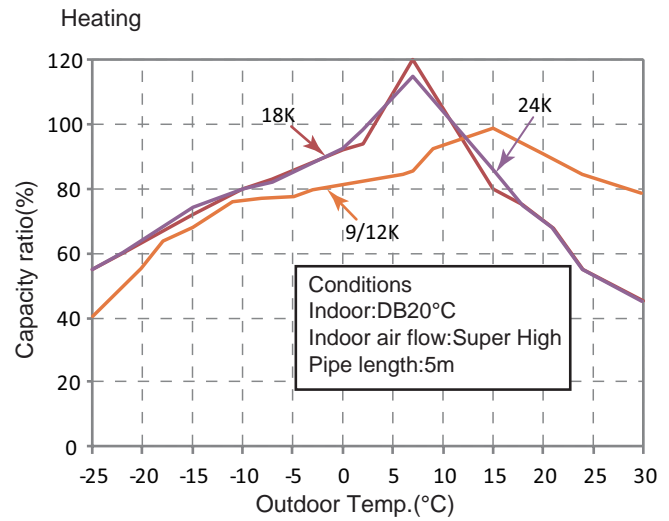
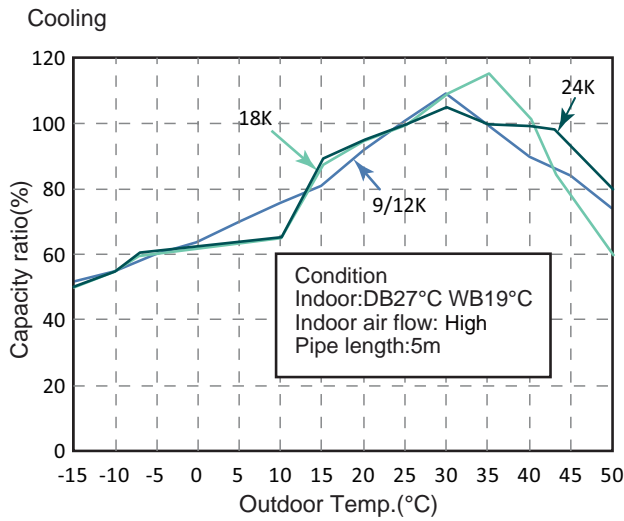

2.3 Cooling and Heating Data Sheet in Rated Frequency

Cooling:

Rated cooling condition(°C) (DB/WB)		Model	Pressure of gas pipe connecting indoor and outdoor unit	Inlet and outlet pipe temperature of heat exchanger		Fan speed of indoor unit	Fan speed of outdoor unit
Indoor	Outdoor			T1 (°C)	T2 (°C)		
27/19	35/24	7/9K	0.8~1.1	12 ~ 15	65 ~ 38	Super High	High
27/19	35/24	12K	0.9~1.1	12 ~ 14	75 ~ 37	Super High	High
27/19	35/24	18K	0.9~1.1	12 ~ 14	75 ~ 37	Super High	High
27/19	35/24	24K	0.9~1.1	12 ~ 14	75 ~ 37	Super High	High

Heating:

Rated heating condition(°C) (DB/WB)		Model	Pressure of gas pipe connecting indoor and outdoor unit	Inlet and outlet pipe temperature of heat exchanger		Fan speed of indoor unit	Fan speed of outdoor unit
Indoor	Outdoor			T1 (°C)	T2 (°C)		
20/-	7/6	7/9K	2.8~3.2	63 ~ 35	2 ~ 5	Super High	High
20/-	7/6	12K	2.2~2.4	70 ~ 35	2 ~ 4	Super High	High
20/-	7/6	18K	2.2~2.4	70 ~ 40	1 ~ 5	Super High	High
20/-	7/6	24K	2.2~2.4	70 ~ 35	2 ~ 4	Super High	High

Instruction:

T1: Inlet and outlet pipe temperature of evaporator

T2: Inlet and outlet pipe temperature of condenser

P: Pressure at the side of big valve

Connection pipe length: 5 m.

3. Outline Dimension Diagram

3.1 Indoor Unit

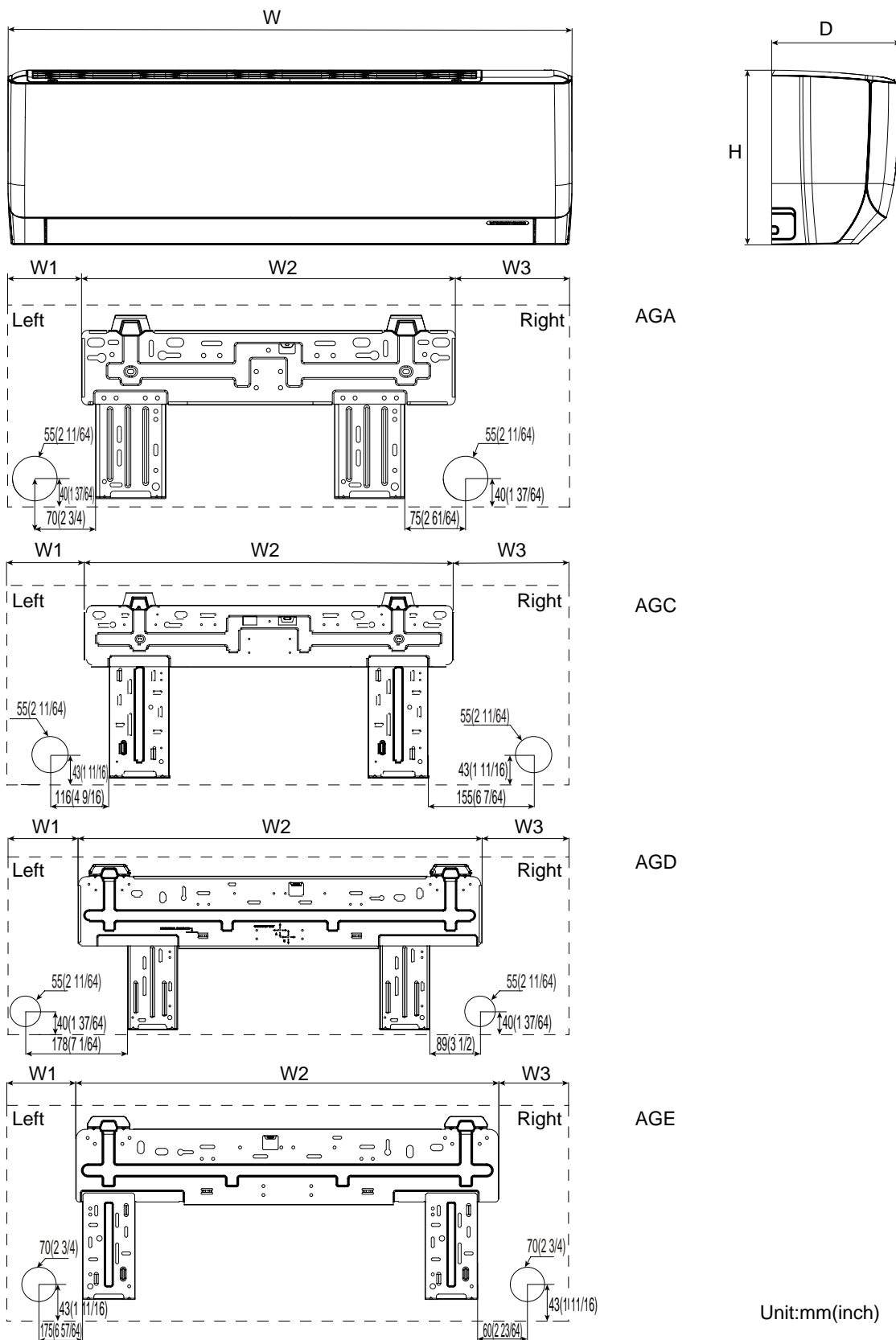

Model	W	H	D	W1	W2	W3
AGA	704	260	185	93	462	149
AGC	825	293	196	113	542	170
AGD	982	311	221	122.5	707.5	152
AGE	1075	333	246	184	707.5	183.5

Unit:mm

GWH18AGD-K6DNA1E/O

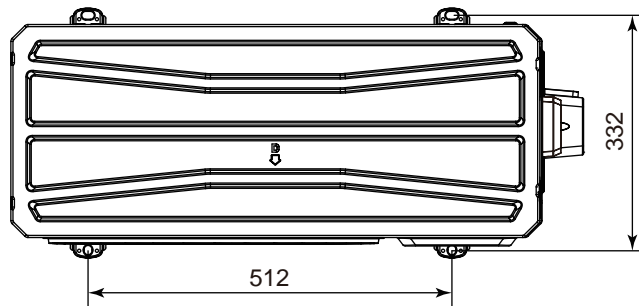
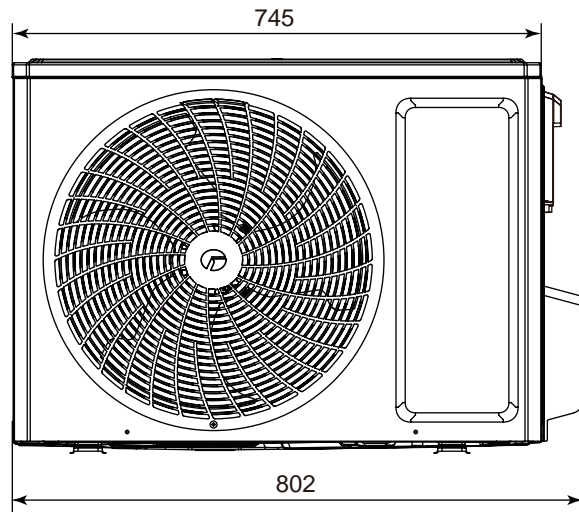
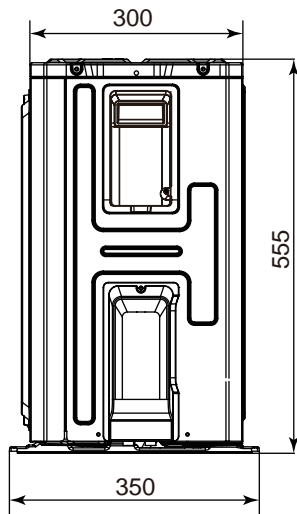

Unit:mm

GWH24AGD-K6DNA1C/O

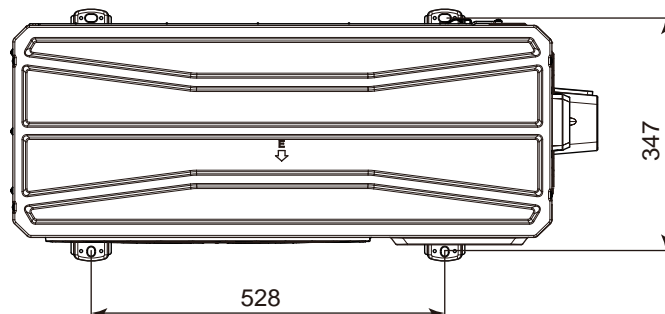
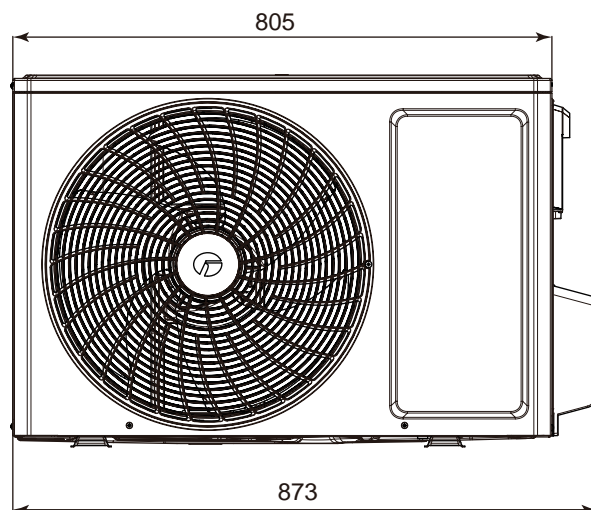
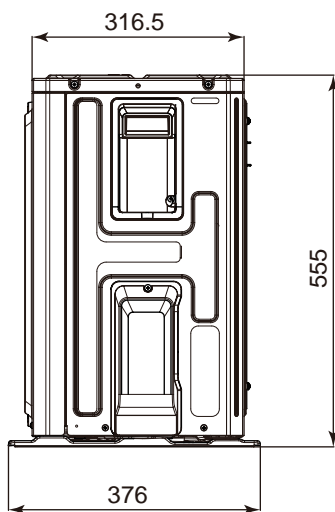

Unit:mm